

SAMPLE CONDITIONING PACKAGE

PRODUCT DATA SHEET—201

Model 31—Intrinsically safe aspirator-driven sampler with vapor condenser
 For solvent-based processing

Introduction

The Neutronics Sample Conditioning Package is designed to ensure that the oxygen sensor always has a clean, dry sample gas for accurate measurement. Process conditions that include solvents, corrosive chemicals, and temperature extremes present significant challenges. To deliver accurate and reliable gas measurement, sensors require a sample that is free of contaminants. Sample conditioning systems built to withstand harsh processing conditions and efficiently remove damaging contaminants from the sample stream are critical to delivering reliable continuous duty low-maintenance gas monitoring.

Operation

The Model 31 Series Sample Conditioning Package uses a pneumatically driven aspirator to extract the sample from the process. Using air or nitrogen as the drive gas, the aspirator produces vacuum by means of the Venturi effect. This vacuum is used to draw the sample gas from a long distance without long lag times in sensor response and to create a bypass flow to flush the vapor condenser of collected condensate. With no moving parts, the aspirator is intrinsically safe. The Model 31 sampler is ideally suited for processes operating at pressures ranging from -25 inH₂O to 5 psig.

To provide the sensor with a continuous clean sample gas flow, many solvent based processes require the removal of varying amounts of entrained vapors. Designed for process temperatures at or slightly above ambient, the integral Neutronics vapor condenser removes solvent and water vapors from the sample gas stream before they can contaminate the sensor. It consists of a heat exchanger powered by a vortex cooler. The vortex cooler provides the refrigeration for the condenser assembly that is used to collect heat from the sample flow and condense entrained vapors.

For processes with high operating temperatures, additional preconditioning components are typically included. The demister (Product Data Sheet 103) and the coalescing prefilter (Product Data Sheet 101) are frequently used to enhance liquid removal and filtration performance.

Available options

Teflon wetted parts
 Explosion proof heat tracing
 NEMA 4 enclosure or panel-only mounting
 Single or dual oxygen sensors
 Single or dual flammable or toxic gas sensors
 Remote calibration valve

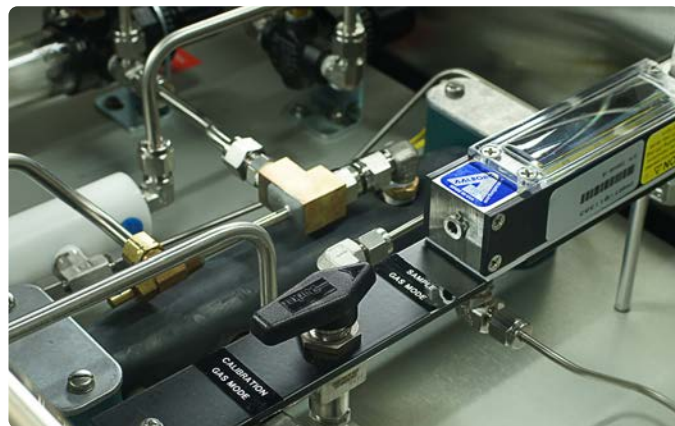

Features

- Intrinsically safe design – with no moving parts, the pneumatically-powered Model 31 sampler is suitable for hazardous area locations
- Corrosion resistant NEMA 4X enclosure – suitable for indoor or outdoor use with protection against ingress of dust and water
- Integral flow switch – opens contacts in alarm when sample gas flow falls below a preset level
- Single or dual sensor compatible – option for redundant dual sensors enhances reliability
- Internal vapor condenser – air-cooled heat exchanger powered by a high efficiency vortex cooler with no moving parts removes contaminants from the sample gas stream
- Low maintenance package – high quality components with few replacement parts minimizes maintenance costs and unplanned downtime

Applications

Process vessels
 Reactors
 Mixers
 Dryers
 Vent header monitoring
 Solvent recovery systems

MODEL 31 SERIES SAMPLE CONDITIONING PACKAGE—SPECIFICATIONS

| | |
|--------------------------|--|
| Sample gas pressure | -25 inH ₂ O to 5 psig |
| Sample gas flow | 5 slpm (±1 slpm) total flow |
| Vortex/venturi drive gas | Instrument quality air or nitrogen 35 psig (min) @ 2 scfm (± 0.5 scfm) |
| Sample filter | 90 micron sintered metal particulate filter |
| Sampling method | 5 slpm flow via 55 inH ₂ O vacuum draw from aspirator/Venturi pump, suitable for applications ranging from -25 inH ₂ O to 5 psig |
| Vacuum capacity | 55 inH ₂ O (± 5 inH ₂ O) |
| Vapor conditioning | Air-cooled vortex-driven vapor condenser with continuous drainage |
| Wetted materials | Stainless steel, glass, Teflon |
| Outside dimensions | 23.62"(w) x 14.96" (h) x 8.6" (d) (600 x 380 x 211mm) |
| Weight | 50 lbs. (22.7 kg) |

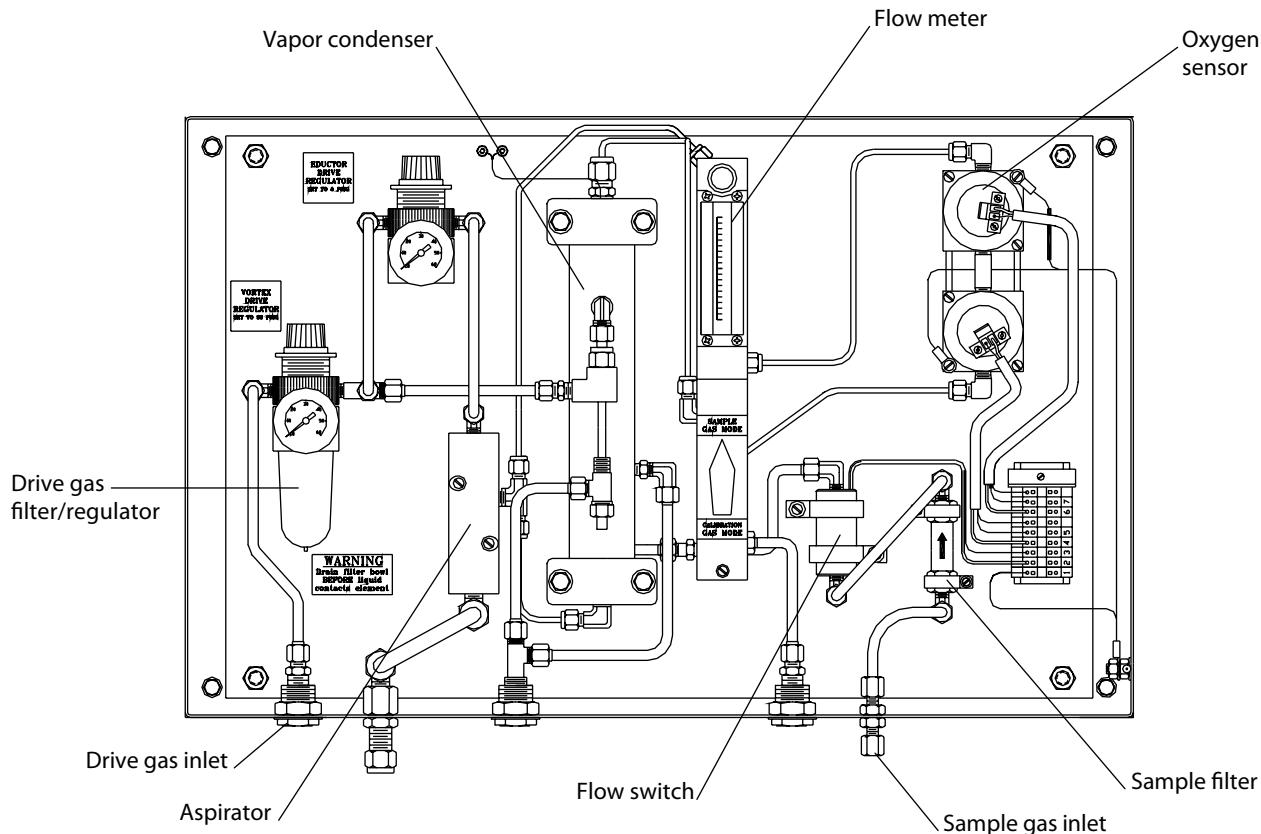

Spare parts

| | |
|-------------------------|---|
| Part No. 4-05-2700-03-0 | Drive gas filter/regulator element |
| Part No. 4-05-2300-07-0 | Sample gas particulate filter 90 micron |

Order information

| | | |
|-------------------------|------------------------|---|
| Part No. 7-04-3000-02-0 | Model 31-609-123000-1 | Single sensor, NEMA 4 enclosure |
| Part No. 7-04-3000-03-0 | Model 31-609-123000-2 | Single sensor, NEMA 4X enclosure |
| Part No. 7-04-3000-03-3 | Model 31-609-123000-2U | Single sensor, NEMA 4X enclosure, UL listed |
| Part No. 7-04-3000-12-0 | Model 31-609-123040-2 | Single sensor, NEMA 4X enclosure, XP heater |
| Part No. 7-04-3000-17-0 | Model 31-669-123000-2 | Dual sensor, NEMA 4X enclosure |



**Neutronics
Gas Analysis Solutions**
456 Creamery Way
Exton, PA 19341

Tel: 610.524.8800
Fax: 610.524.8807
Email: info@neutronicsinc.com

www.analyzegas.com



SAMPLE CONDITIONING PACKAGE

PRODUCT DATA SHEET—202

Model 31—Intrinsically safe aspirator-driven sampler

For powder processing and handling

Introduction

The Neutronics Sample Conditioning Package is designed to ensure that the oxygen sensor always has a clean, dry sample gas for accurate measurement. Process conditions that include corrosive chemicals, temperature extremes, and powders present significant challenges. To deliver accurate and reliable gas measurement, sensors require a sample that is free of contaminants. Sample conditioning systems built to withstand harsh processing conditions and efficiently remove damaging contaminants from the sample stream are critical to delivering reliable continuous duty low-maintenance gas monitoring

Operation

The Model 31 Sample Conditioning Package uses a pneumatically driven aspirator to extract the sample from the process. Using air or nitrogen as the drive gas, the aspirator produces vacuum by means of the Venturi effect. This vacuum is used to draw the sample gas from a long distance without long lag times in sensor response. With no moving parts, the aspirator is intrinsically safe. The Model 31 sampler is ideally suited for processes operating at pressures ranging from -25 inH₂O to 5 psig.

To provide the sensor with a continuous clean sample gas flow, most powder processing systems require the removal of varying amounts of particulates. For these systems, external preconditioning components are typically included. The blowback filter (Product Data Sheet 105) and the coalescing prefilter (Product Data Sheet 101) provide high filtration performance along with high stability, exceptional dirt holding capacity, and high flow rates with low pressure drop.

Available options

Teflon wetted parts

Explosion proof heat tracing

NEMA 4 enclosure or panel-only mounting

Single or dual oxygen sensors

Single or dual flammable or toxic gas sensors

Remote calibration valve



Features

- Intrinsically safe design – with no moving parts, the pneumatically-powered Model 31 sampler is suitable for hazardous area locations
- Corrosion resistant NEMA 4X enclosure – suitable for indoor or outdoor use with protection against ingress of dust and water
- Integral flow switch – opens contacts in alarm when sample gas flow falls below a preset level
- Single or dual sensor compatible – option for redundant dual sensors enhances reliability
- Low maintenance package – high quality components with few replacement parts minimizes maintenance costs and unplanned downtime
- Continuous duty – external high efficiency filter units remove particulates and contaminants from the sample gas stream

Applications

Mills

Dryers

Blenders and mixers

Conveyors and feeders

Hoppers, bins and receivers

Reactors and process vessels

MODEL 31 SERIES SAMPLE CONDITIONING PACKAGE—SPECIFICATIONS

| | |
|---------------------|---|
| Sample gas pressure | -25 inH ₂ O to 5 psig |
| Sample gas flow | 5 slpm (± 1 slpm) total flow |
| Venturi drive gas | Instrument quality air or nitrogen 35 psig (min) @ 2 scfm (± 0.5 scfm) |
| Sample filter | External cartridge or sintered metal filter |
| Sampling method | 5 slpm flow via 55 inH ₂ O vacuum draw from venturi aspirator/venturi pump, suitable for application ranging from -25 inH ₂ O to 5 psig |
| Vacuum capacity | 55 inH ₂ O (± 5 inH ₂ O) |
| Wetted materials | Stainless steel, glass, Teflon |
| Enclosure | 23.31" w x 14.96" h x 8.3" d (356 x 406 x 155 mm) |
| Weight | 35 lbs. (15.8 kg) |

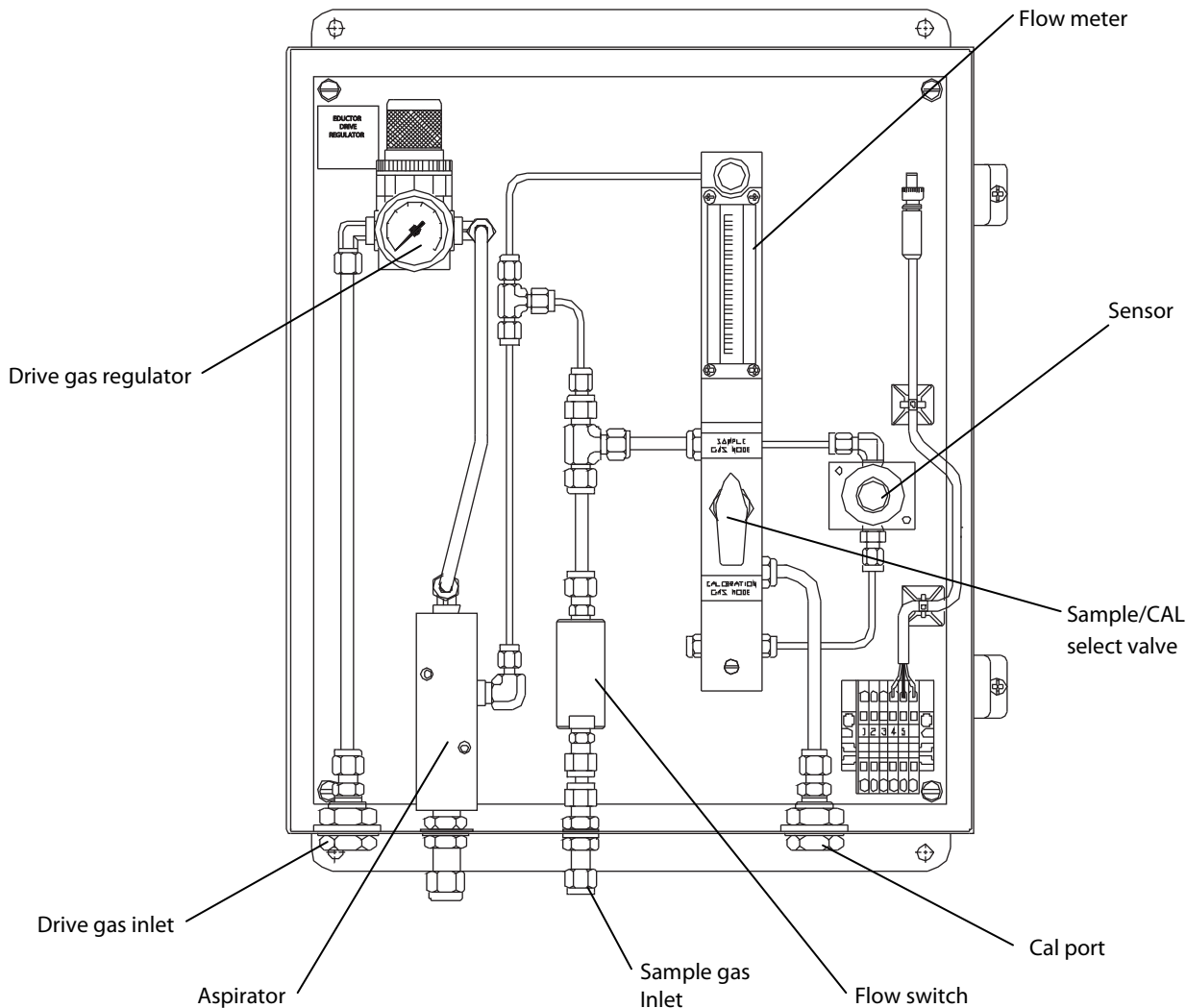

Order information

Part No. 7-04-3100-43-0
Part No. 7-04-3100-65-0

Model 31-609-023000-2S
Model 31-609-023000-2

NEMA 4 enclosure, with prefilter
NEMA 4X enclosure, without prefilter



**Neutronics
Gas Analysis Solutions**
456 Creamery Way
Exton, PA 19341

Tel: 610.524.8800
Fax: 610.524.8807
Email: info@neutronicsinc.com

www.analyzegas.com



SAMPLE CONDITIONING PACKAGE

PRODUCT DATA SHEET—203

Model 21— Inherently safe positive pressure driven sampler

For solvent-based processing

Introduction

The Neutronics Model 21 Sample Conditioning Package is designed to ensure that the oxygen sensor always has a clean, dry sample gas for accurate measurement. Process conditions that include solvents, corrosive chemicals, and temperature extremes present significant challenges. To deliver accurate and reliable gas measurement, sensors require a sample that is free of contaminants. Sample conditioning systems built to withstand harsh processing conditions and efficiently remove damaging contaminants from the sample stream are critical to delivering reliable continuous duty low-maintenance oxygen monitoring.

Operation

For the Model 21 Series Sample Conditioning Package, continuous positive pressure in the process vessel or system provides the force that pushes the sample gas from the process to the sensor. Suitable for applications with process operating pressures between 5 and 300 psig, the Model 21 Series sampler includes a pressure reducing regulator to control the pressure and flow of the sample gas through the system.

To provide the sensor with a continuous clean sample gas flow, many solvent based processes require the removal of varying amounts of entrained vapors. Designed for process temperatures at or slightly above ambient, the integral Neutronics vapor condenser removes solvent and water vapors from the sample gas stream before they can contaminate the sensor. It consists of a heat exchanger powered by a vortex cooler. The vortex cooler provides the refrigeration for the condenser assembly that is used to collect heat from the sample flow and condense entrained vapors. The vapor condenser is pneumatically powered. A vortex drive filter/regulator is included in the sample package to regulate the drive gas to 30 psig.

For processes with high operating temperatures, additional preconditioning components are typically included. The demister (Product Data Sheet 103) and the coalescing prefilter (Product Data Sheet 101) are frequently used to enhance liquid removal and filtration performance.

Available Options

NEMA 4 enclosure or panel-only mounting

Teflon wetted parts

Explosion proof heat tracing

Remote calibration valve

Single or dual oxygen sensors

Single or dual flammable or toxic gas sensors



Features

- Inherently safe design – with no moving parts, the pneumatically-powered Model 21 sampler is suitable for hazardous area locations
- Corrosion resistant NEMA 4X enclosure – suitable for indoor or outdoor use with protection against ingress of dust and water
- 316L pressure reducing regulator – controls the pressure and flow of the sample gas for applications with operating pressures up to 300 psig
- Integral flow switch – opens contacts in alarm when sample gas flow falls below a preset level
- Single or dual sensor compatible – option for redundant dual sensors enhances reliability
- Internal vapor condenser – high efficiency vortex cooler with no moving parts removes contaminants from the sample gas stream
- Low maintenance package – high quality components with few replacement parts minimizes maintenance costs and unplanned downtime

Applications

Process vessels

Reactors

Mixers

Dryers

Vent header monitoring

Solvent recovery systems

MODEL 21 SERIES SAMPLE CONDITIONING PACKAGE—SPECIFICATIONS

| | |
|---------------------|--|
| Sample gas pressure | 5 to 300 psig |
| Sample gas flow | 5 slpm (± 1 slpm) total flow |
| Venturi drive gas | Instrument quality air or nitrogen, 35 psig (min.) @ 2 scfm (± 0.5 scfm) |
| Sample filter | 90 micron sintered metal, 316 SS |
| Sampling method | Positive pressure package with pressure reducing regulator, suitable for applications ranging from 5 to 300 psig |
| Vapor conditioning | Air-cooled vortex-driven vapor condenser with continuous drainage |
| Wetted materials | Stainless steel, glass, Teflon |
| Outside dimensions | 23.62" (w) x 14.96" (h) x 8.6" (d) (600 x 380 x 211 mm) |
| Weight | 50 lbs. (22.7 kg) |

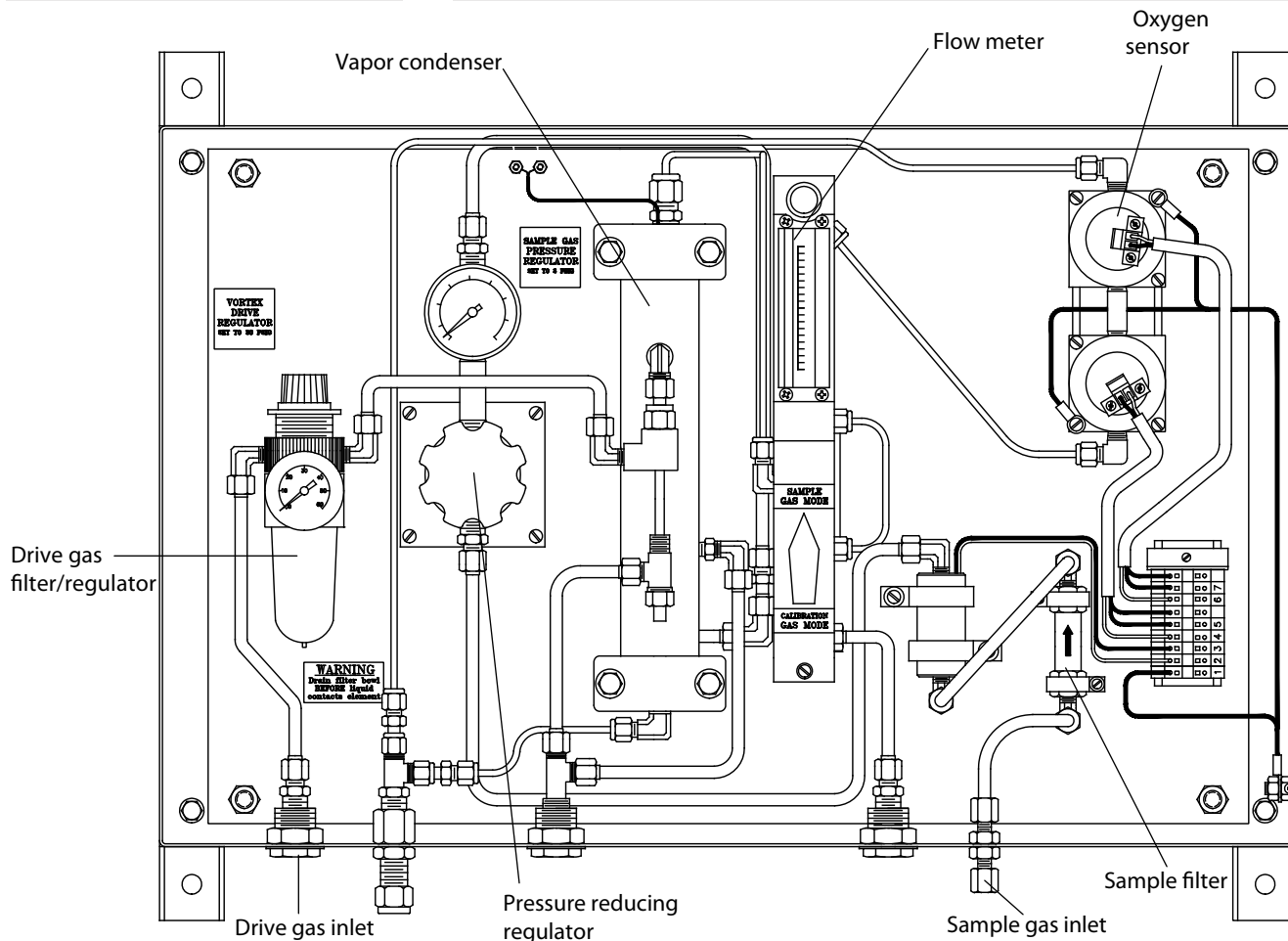

Spare parts

| | |
|-------------------------|---|
| Part No. 4-05-2700-03-0 | Drive gas filter regulator element |
| Part No. 4-05-2300-07-0 | Sample gas particulate filter 90 micron |

Order information

| | | |
|-------------------------|-------------------------|---|
| Part No. 7-04-2000-01-2 | Model 21-609-123000-1 | Single sensor, NEMA 4 enclosure |
| Part No. 7-04-2000-09-0 | Model 21-609-123000-2 | Single sensor, NEMA 4X enclosure |
| Part No. 7-04-2000-09-1 | Model 21-609-123000-2UL | Single sensor, NEMA 4X enclosure, UL listed |
| Part No. 7-04-2000-12-0 | Model 21-669-123000-2 | Dual sensor, NEMA 4X enclosure |
| Part No. 7-04-2000-26-0 | Model 21-669-123000-2UL | Dual sensor, NEMA 4X enclosure, UL listed |

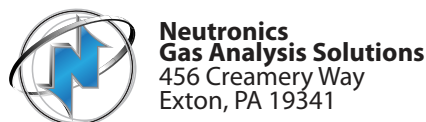

Tel: 610.524.8800
Fax: 610.524.8807
Email: info@neutronicsinc.com

www.analyzegas.com

